

CL - xx - xPx - G - xx - S - R - N - xx - A - A - A - 0 - 0

Hood body material	
SW	SteelWhite RAL9010
S4	SS 304
S6	SS 316L

Filter front size	
3P3	305x305
3P6	305x610
4P4	457x457
5P5	508x508
6P6	610x610
9P6	915x610
9P9	915x915
11P5	1108x508
12P6	1220x610

Filter frame height	
	MD-66 (Standard)
	MX-90
	MG-110

Entry pos.	
00	All square
LS	Long side
SS	Short side

Customization		
X	0	None (Standard)
	9	Custom

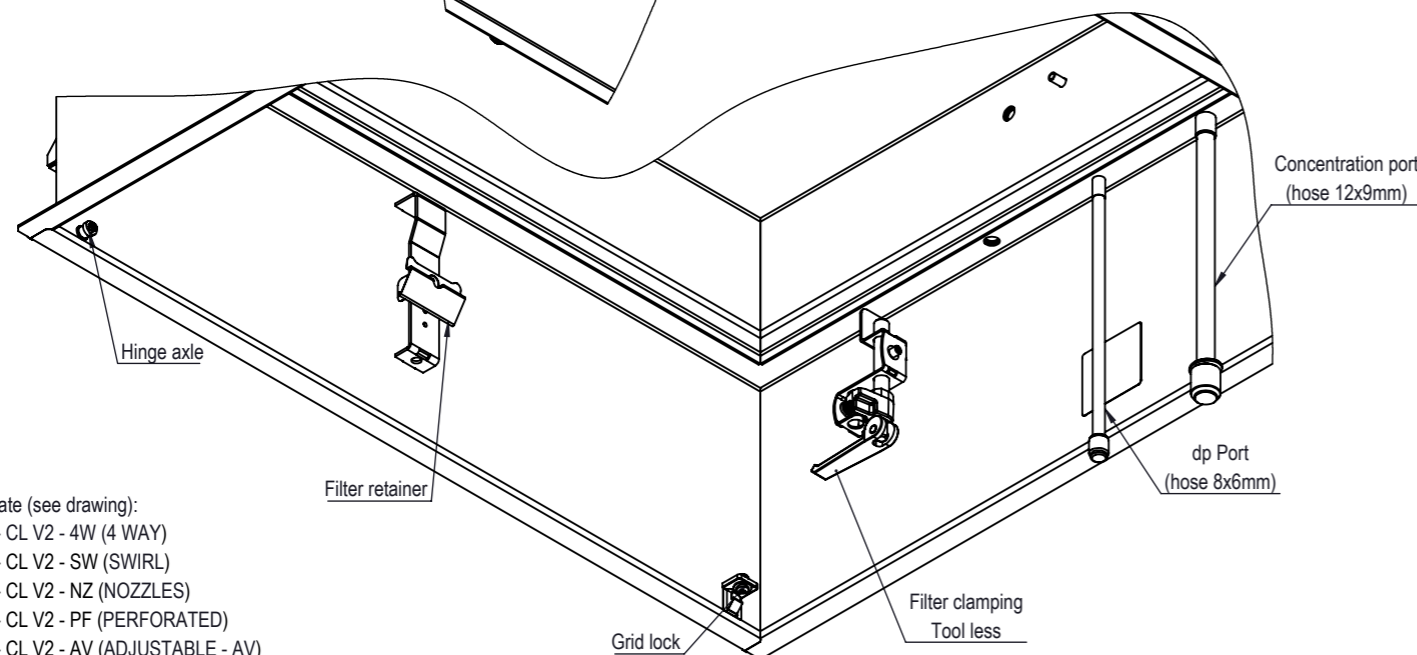
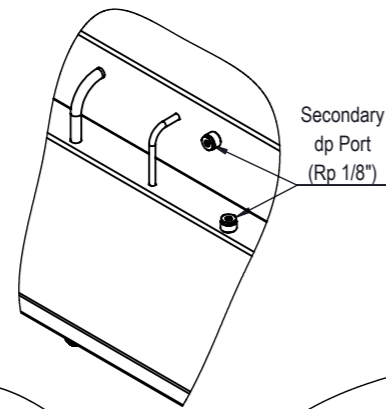
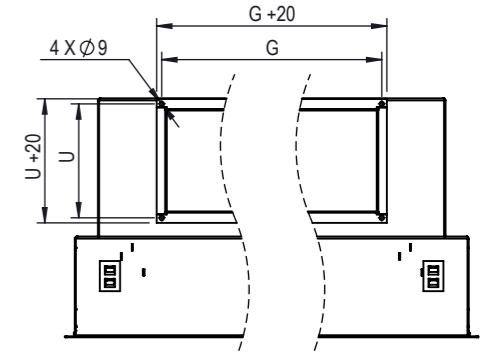
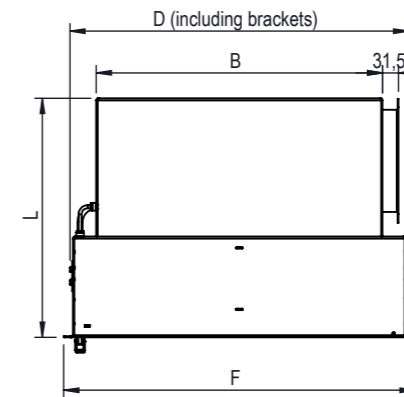
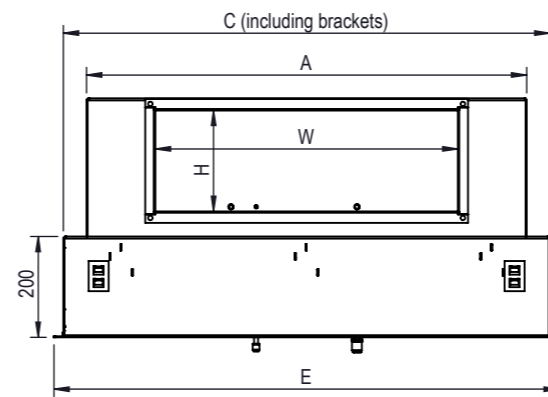
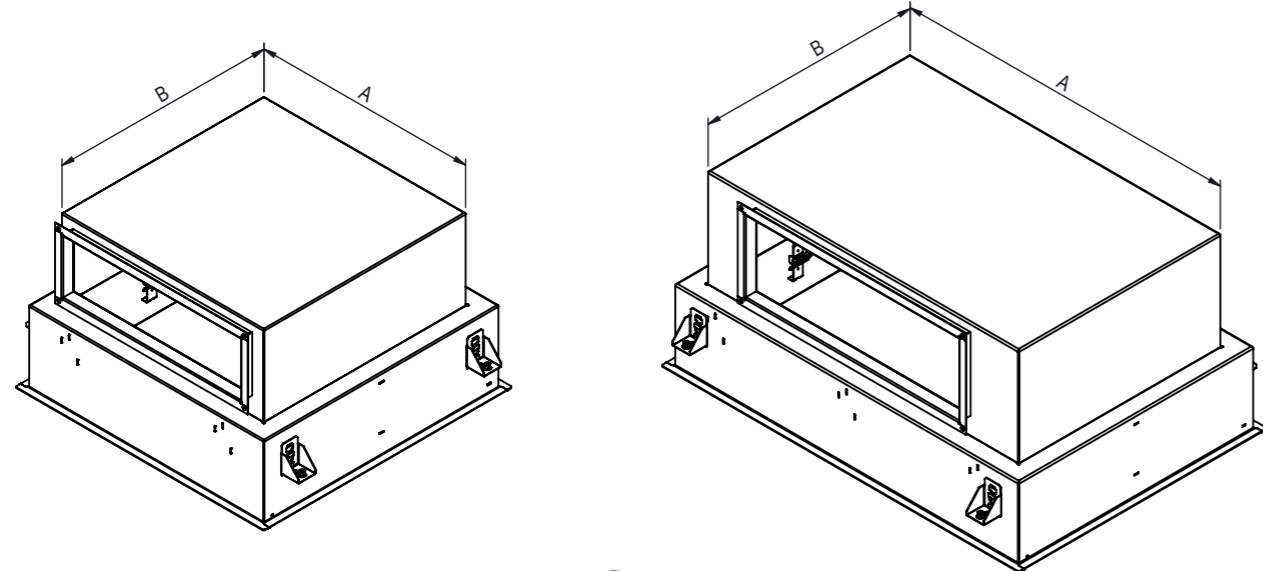
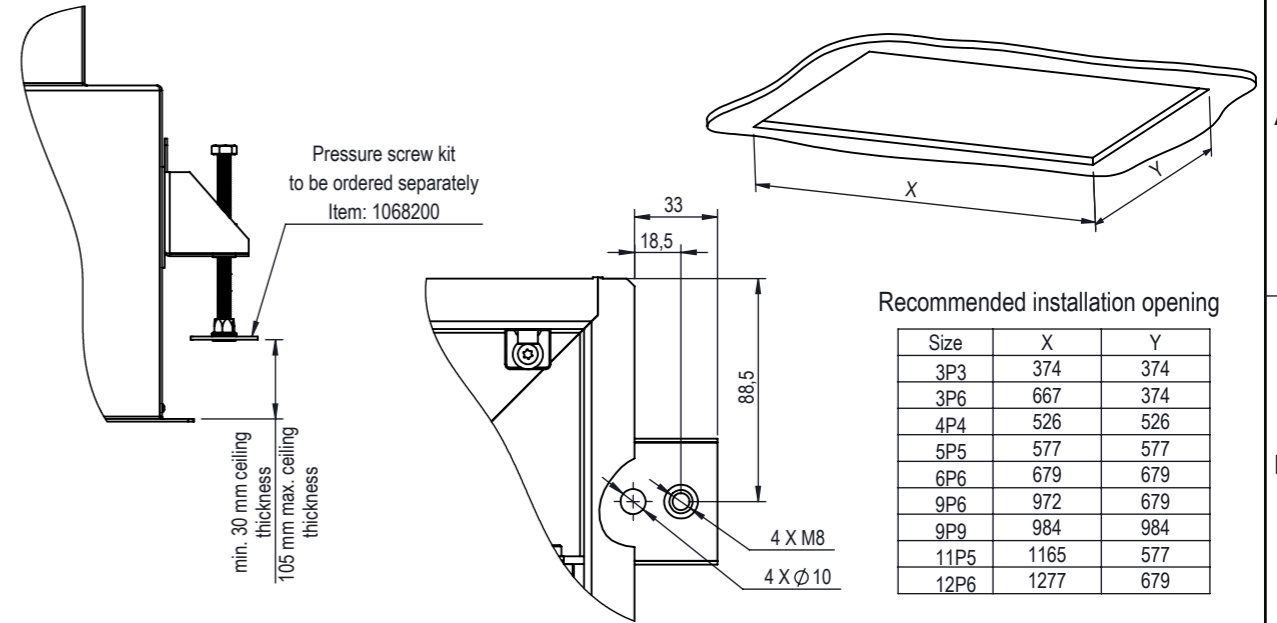

	Opening W x H	CAD Reference	L	A	B	C	D	E	F	G x U		Weight [kg]
3P3	200 100	CL-V3-3P3-G-S-R-200x100	374	263	263	367	355	392	392	220	126	9
3P6	350 100	CL-V3-3P6-G-S-R-350x100-LS	374	568	263	660	367	697	392	370	126	13
	200 200	CL-V3-3P6-G-S-R-200x200-SS	474							220	226	15
4P4	350 150	CL-V3-4P4-G-S-R-350x150	424	415	415	519	507	544	544	370	176	14
5P5	400 150	CL-V3-5P5-G-S-R-400x150	424	466	466	570	558	595	595	420	176	16
6P6	500 150	CL-V3-6P6-G-S-R-500x150	424	568	568	672	660	697	697	520	176	20
9P6	600 200	CL-V3-9P6-G-S-R-600x200-LS	474	873	568	965	672	1002	697	620	226	35
	500 200	CL-V3-9P6-G-S-R-500x200-SS								520	226	
9P9	600 200	CL-V3-9P9-G-S-R-600x200	474	873	873	977	965	1002	1002	620	226	45
11P5	800 150	CL-V3-11P5-G-S-R-800x150-LS	474	1066	466	1158	570	1195	595	820	176	34
	400 200	CL-V3-11P5-G-S-R-400x200-SS								420	226	
12P6	800 150	CL-V3-12P6-G-S-R-800x150-LS	474	1178	568	1270	672	1307	697	820	176	41
	500 200	CL-V3-12P6-G-S-R-500x200-SS								520	226	

- Compatible Front plate (see drawing):
- Customer Drawing - CL V2 - 4W (4 WAY)
 - Customer Drawing - CL V2 - SW (SWIRL)
 - Customer Drawing - CL V2 - NZ (NOZZLES)
 - Customer Drawing - CL V2 - PF (PERFORATED)
 - Customer Drawing - CL V2 - AV (ADJUSTABLE - AV)
 - Customer Drawing - CL V2 - SW adj (SWIRL - ABS ADJUSTABLE)



DESCRIPTION			
CleanSeal - GEL - Side Rectangular			
PROJECT	LAST REVISION	WEIGHT	
DRAWING REF.	SHEET	SIZE	
Scope Drawing - CL-V3-G-S-R	1/1	A3	SCALE

NB: The copyright of this drawing remains with Camfil. Contents must not be used, copied or disclosed to third parties without prior written consent. All rights reserved.